



Our patented JN Series hydraulic wrench is designed specifically for fast, safe, and accurate tightening or loosening of Top Drive Packing Nuts and Gas Compressor Piston Rod Crosshead Jam Nuts.

In-house specialty adapters/inserts can be used with the JN Series to turn any nut that faces the problem of having a shaft, rod or tube running through its center.

The JN Series features a patented “split-head” design, enabling the tool to fit over the wash pipe or piston rod and around your packing nut or jam nut.

**PATENTED**

## **SPLIT HEAD**

The “split-head” itself, or through use of special made adapter/ insert, can fit any size or type of Top Drive Packing Nut, OEM Jam Nut, hex or any other configuration, eliminating the need for expensive after market nuts giving you never-before-seen accuracy, speed and safety.

## **FAST**

The patented “split-head” design can be placed around the wash pipe, piston rod, or any other type of shaft, rod, pipe, or tube and on the nut or adapter/ insert in less than one minute. Accurate tightening or loosening of the jam nut is easily achieved in just a few seconds.

## **SAFE**

The JN Series hydraulic wrench eliminates unsafe hammer wrenches, hydraulic jacks or cranes, and other unsafe equipment currently being used to turn these nuts.

## **ACCURATE**

This fast hydraulic wrench, provides accuracy to +/- 0.03 with the use of a standard bi-directional 10,000 p.s.i. hydraulic pump.

## **FUNCTIONAL**

The JN Series hydraulic wrench will work equally well in either Top Drive wash pipe assemblies or compressor crosshead access ports. It will work right-side up, upside-down, sideways, etc. – for both loosening and tightening.

**PATENTED**

## **360° SWIVELS**

Our patented 360° swivels rotate on both axis, giving the operator enhanced control and increased maneuverability while using the tools. Hose binding is all but eliminated with this nickel-plated swivel design.

## **CALIBRATED**

Every tool is tested and calibrated to +/- 0.03 accuracy and +/- 0.01 repeatability traceable to N.I.S.T. standards.



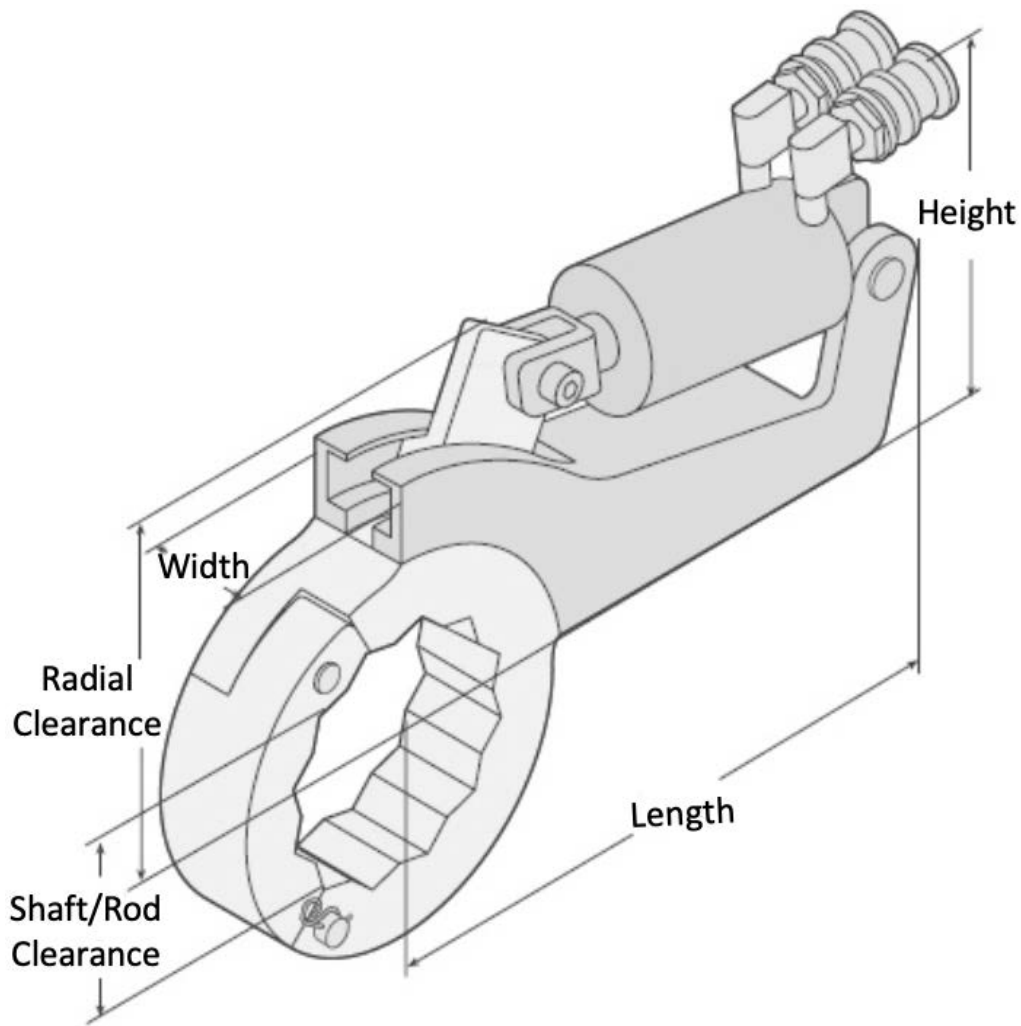

JN SERIES	MAX FT. LBS. @ 10,000 PSI	LENGTH	HEIGHT	WIDTH	RADIAL CLEARANCE	"SPLIT HEAD" RANGE	WEIGHT WITH HEAD
JN-4	3,650	13.044"	7.014"	1.950"	5.000"	2" - 4 <sup>5</sup> / <sub>8</sub> "	28 lbs.
JN-10	8,400	10.659"	7.014"	1.950"	5.000"	3 <sup>3</sup> / <sub>8</sub> " - 4 <sup>5</sup> / <sub>8</sub> "	28 lbs.
JN-20	20,100	14.056"	9.117"	1.950"	7.372"	4 <sup>5</sup> / <sub>8</sub> " - 6"	40 lbs.
JN-30	32,000	16.000"	10.446"	1.950"	8.825"	6" - 8 <sup>1</sup> / <sub>4</sub> "	57 lbs.
JN-40	38,396	19.126"	12.500"	2.950"	10.070"	4 <sup>5</sup> / <sub>8</sub> " - 10"	105 lbs

# LOWER CROSSHEAD SLIDE

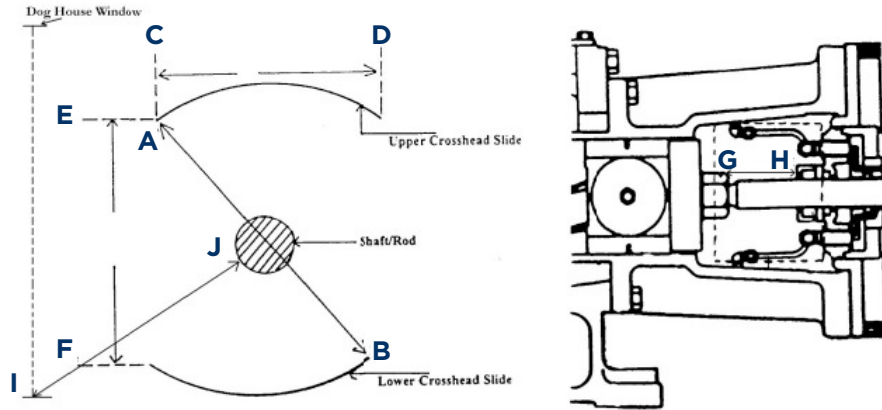

## COMPANY INFORMATION

Order Number \_\_\_\_\_ Date \_\_\_\_\_  
Contact Name \_\_\_\_\_ Title \_\_\_\_\_ Phone \_\_\_\_\_  
Company \_\_\_\_\_ Fax \_\_\_\_\_  
Address \_\_\_\_\_  
City \_\_\_\_\_ State \_\_\_\_\_ Zip \_\_\_\_\_

## COMPRESSOR INFORMATION

Compressor Manufacturer/Brand \_\_\_\_\_  
Compressor Model/Series \_\_\_\_\_

## JAM NUT INFORMATION

Jam Nut Manufacturer \_\_\_\_\_  
Jam Nut Part Number \_\_\_\_\_  
Thread Opening \_\_\_\_\_  
Thread Count per Inch \_\_\_\_\_  
Description Shape & Size (O.D.) of Nut \_\_\_\_\_  
Max. Make-up Torque (ft./lbs.) \_\_\_\_\_

## DIMENSION INFORMATION

Shaft/Rod Diameter \_\_\_\_\_  
Dimensions A-B \_\_\_\_\_ C-D \_\_\_\_\_ E-F \_\_\_\_\_  
Doghouse (Access Window) Dimensions \_\_\_\_\_  
Inside Doghouse Dimensions G-H \_\_\_\_\_  
I-J \_\_\_\_\_  
Tracking Number of Shipment \_\_\_\_\_ Date Shipped \_\_\_\_\_





The JNAHC-AHR series pump is a rotary style air motor and should be used where air is the preferred source of energy. It has a 3hp motor when it is starting under full load and two-speed operation for rapid cylinder advance. This pump features a remote with full control over advance and return. The tandem center holds the load when the pump is shut off.

CONTINUOUS DUTY

ADVANCE, HOLD & RETRACT OPERATION

46-55 CUBIC IN./MIN.

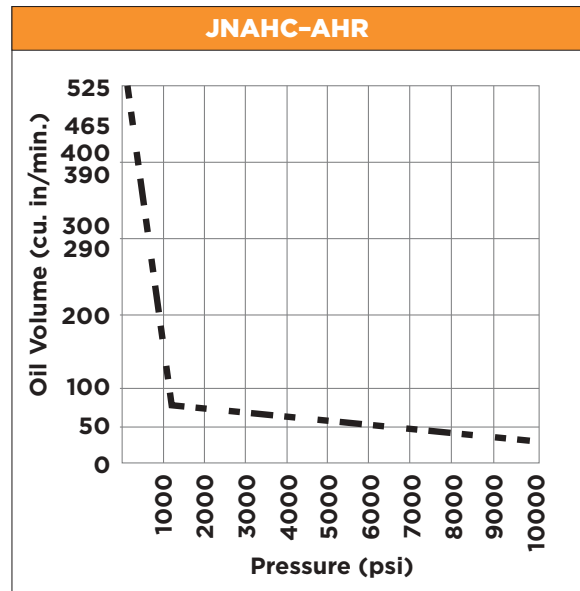
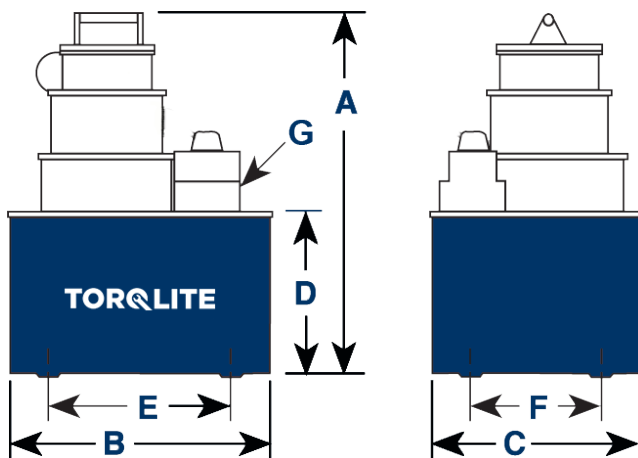

PUMP No.	A (in.)	B (in.)	C (in.)	D (in.)	E (in.)	F (in.)	G (in.)	MAX PRESSURE Output (psi)	10 (psi)	100 (psi)	1,000 (psi)	5,000 (psi)	10,000 (psi)
JNAHC-AHR	15	11-1/2	9-1/2	7	10	8	3/8 NPTF	10,000	465	450	53	51	46





The JNEHC-10 is a heavy duty electric pump made for multiple applications with a low voltage starting potential. The pump features a 10' remote motor control with full control over advance, hold and retract operations. The tandem center holds the load when the pump is shut off. True unloading valve achieves greater pump efficiency, allowing higher flow at maximum pressure.

\*\*Pump shown is with a 4-port manifold. Sold with single port manifold.

**NOT TO BE USED FOR LIFTING APPLICATIONS.**

**LIGHT WEIGHT AND PORTABLE**

**1-1/8 HP, 12,000 RPM, 230 VOLT, 50/60 HZ UNIVERSAL MOTOR; DRAWS 15 AMPS AT FULL LOAD, STARTS AT REDUCED VOLTAGE**

**2 1/2 GALLON RESERVOIR**

4 mounting holes 1/2"-20

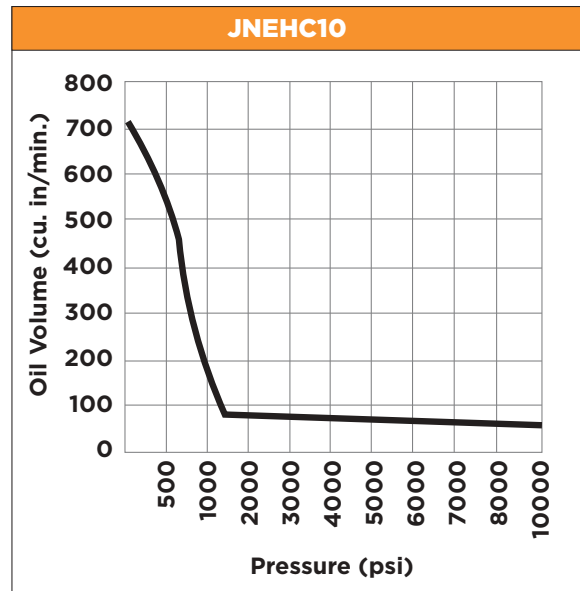
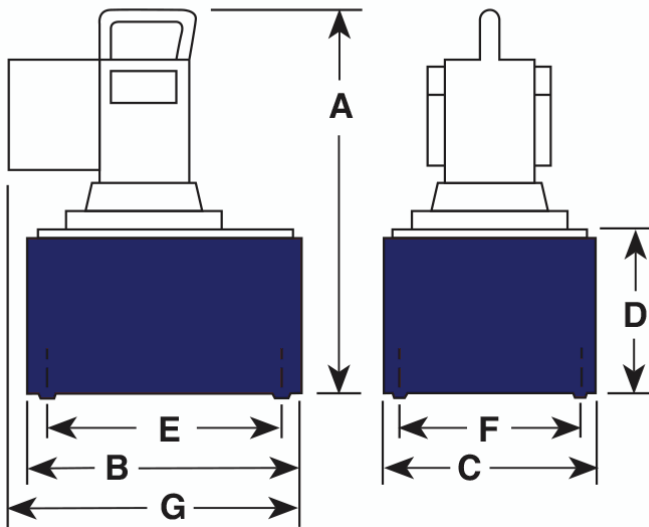

PUMP No.	A (in.)	B (in.)	C (in.)	D (in.)	E (in.)	F (in.)	G (in.)	MAX PRESSURE Output (psi)	0 (psi)	700 (psi)	5,000 (psi)	10,000 (psi)
JNEHC10	18-1/4	11-1/2	9-1/2	7	10	8	14	10,000	704	440	74	56

