



TorqLite's patented HU Tool clamping wrench is designed specifically to work on Hammer Union connections while eliminating the need for the hammer the connections were named for.

The new and improved HU wrench is capable of fitting all registered Hammer Union sizes. The easy-to-latch heads make installation and set-up simple, while the spring loaded action provides nearly a completely hands-free operation.

PATENTED SPRING HEAD

The head features the same patented open-gate design as TorqLite's JN Series wrenches, but has a spring-latch feature that makes applying and removing the tool very simple. Fixed to the inside of the head are the jaws, used to clamp the pipe.

SAFE

The safety increases exponentially when you remove a hammer from a situation and add a tool that does not require a dangerous swinging motion to operate.

INTERCHANGEABLE HEADS

With only the need for one HU Tool, our interchangeable heads are the only thing you'll need to be changing when tightening or loosening Hammer Union connections. Each head includes a welded jaw that clamps to the application and turns as it advances for a more efficient way to work. The HU Tool and our entire range of interchangeable heads will fit on all registered Hammer Union connections.

NON DESTRUCTIVE

Throughout their lifespan, the Hammer Union lugs can take a lot of beatings - literally. The HU Tool reduces the impact on those lugs and eliminates the damage caused by the hammers, saving replacement time and costs.

ADJUSTABLE REACTION

The adjustable reaction arm allows the HU Tool to fit all registered Hammer Union connections.

NO HANDS

Once the tool is applied to the Hammer Union connection, the operator does not need to use his hands to hold the tool in place. Alternatively if the operator so chooses, a handle is provided so that he can hold the tool safely.

CONTROLLED LOAD

Since the operator is not striking a hammer, the load is able to be applied to the connection in a stable, constant, and controlled manner.



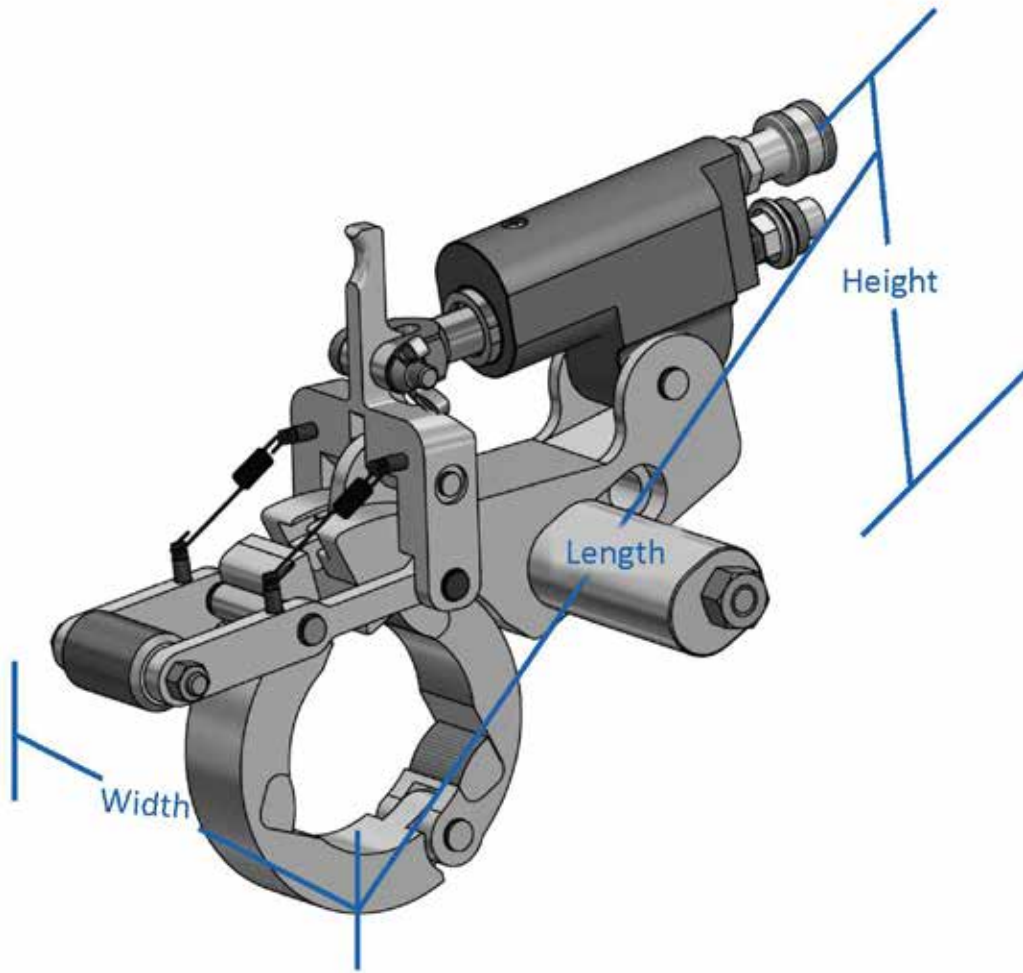

SERIES	TOOL LENGTH*	TOOL HEIGHT	TOOL WIDTH	REACTION BAR WIDTH	COMBINED WIDTH	"SPLIT HEAD" RANGE
HU	14 ⁷ / ₈ " - 16 ¹⁵ / ₁₆ "	10 ⁵ / ₈ "	3 ¹ / ₂ "	3 ³ / ₄ "	5 ¹¹ / ₁₆ "	1 ³ / ₄ " - 6 ¹ / ₂ "

*DEPENDENT ON HEAD SIZE

The HU Tool will work on any standard torque wrench pump, eliminating the need to purchase a special unit to operate it.



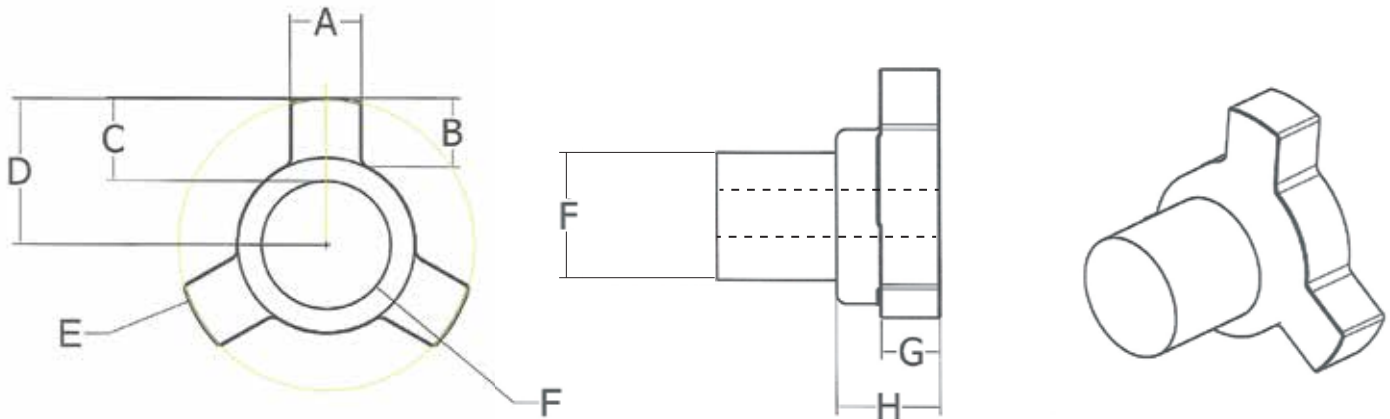

COMPANY INFORMATION

Order Number _____ Date _____

Contact Name _____ Title _____ Phone _____

Company _____ Fax _____

Address _____

City _____ State _____ Zip _____

HAMMER UNION INFORMATION

Manufacturer _____ Fig No. _____

(i.e., NOV 2004, WECCO 1502. Most measurements are available with the make and model. If not please provide the requested dimensions below.)
(*Nominal Pipe Size)

(A) Lug Width _____ (E) Nut Diameter _____

(B) Lug Length _____ (F) O.D. of Pipe size _____

(C) Total Lug Length _____ (G) Lug Width _____

(D) Nut Radius _____ (H) Total Width _____

