

TSR+ AUTO RETURN TENSIONERS

FASTEST AUTO RETURN TENSIONER ON THE MARKET



Latest technology
and innovation



Tighten to accurate
preload



Significant time and
labor savings



Improved
durability

TSR+ FEATURES

FASTEST AUTO RETURN TENSIONER ON THE MARKET

The all new TSR+ auto return tensioner range has been designed to ensure fast, simple, safe and reliable operation. With a focus on productivity and a reduction in downtime we have implemented state of the art materials and technology resulting in significant time saving during operation.



Interchangeable

TSR+ load cells have exactly the same overall dimensions and hydraulic specification as the existing TSR load cells. This ensures interchangeability and ease of customer upgrades to the new range.

Durable

Operational performance does not degrade during the life of the tool. Extensive in-house tests at full stroke and full pressure have shown that it far out performs current TSR load cells.

Increased Safety

TSR+ Load cells have a relief valve to prevent accidental overstroke of the tool. This safety mechanism prevents seal blow outs and the users exposure to ejected oil.

Premium Surface Treatment

All load cells have TorqLite's unique surface finish which provides a long lasting finish against harsh environments.

Improved seal technology

Latest design eases seal changeouts and enhances general performance throughout high cycle usage.

Options

- Twin port hydraulic connections
- Oversized threads
- Gear drive nut rotation
- Swivel connectors
- Special designs

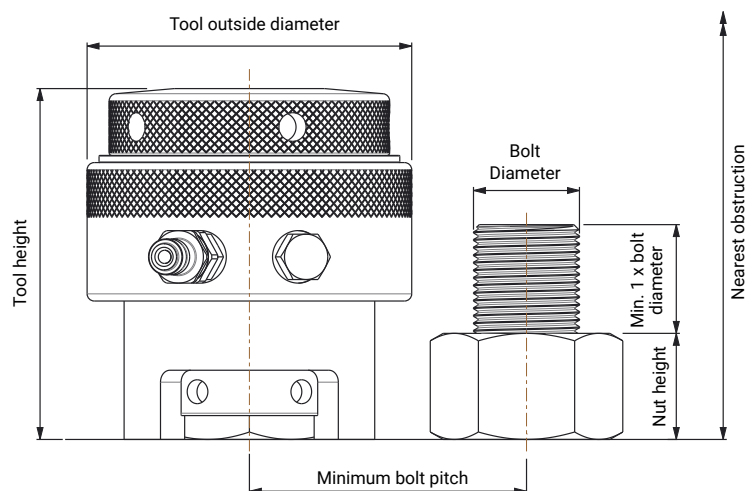

TECHNICAL & DIMENSIONAL SPECIFICATION

Tensioner Design Single acting cylinder, auto return

Maximum Operating Pressure 1500bar (21750psi)

Stroke 10mm (0.375") except TSR+ 0 – 8mm (0.315")

Hydraulic Oil Type ISO 32 or equivalent

Tool No.	Bolt diameter		Hydraulic area mm ²	Max. load		Tool outside diameter		Tool height		Distance to nearest obstruction		Total tool weight		Load cell weight	
	mm	inch		kN	Lbf	mm	inch	mm	inch	mm	inch	kg	lbs	kg	lbs
TSR+ 0*	M20	3/4	1,070	160	35,970	66	2.60	93	3.66	142	5.59	1.4	3.1	1	2.2
	M22	7/8						93	3.66	144	5.67				
TSR+ 1	M24	1	1,870	280	62,950	87	3.43	117	4.61	175	6.89	4.0	8.8	2.4	5.3
	M27	1 1/8						117	4.61	178	7.01				
	—	—						120	4.72	178	7.01				
TSR+ 2	M24	1	3,000	450	101,160	103	4.06	117	4.61	175	6.89	5.8	12.8	3.3	7.3
	M27	1 1/8						117	4.61	178	7.01				
	M30	1 1/4						120	4.72	184	7.24				
	M33	1 3/8						123	4.84	190	7.48				
	M36	—						126	4.96	196	7.72				
TSR+ 3	M33	1 1/4	4,400	660	148,370	118	4.65	123	4.84	192	7.56	7.7	17	4.2	9.3
	M36	1 3/8						126	4.96	198	7.80				
	M39	1 1/2						130	5.12	204	8.03				
	M42	1 5/8						133	5.24	211	8.31				
TSR+ 4	M39	1 1/2	6,670	1,000	224,810	141	5.55	132	5.20	212	8.35	12.0	26.5	6.1	13.4
	M42	1 5/8						135	5.31	218	8.58				
	M45	1 3/4						139	5.47	225	8.86				
	M48	1 7/8						142	5.59	231	9.09				
	—	2						145	5.71	231	9.09				
TSR+ 5	M52	2	10,000	1,500	337,210	176	6.93	148	5.83	248	9.76	19.4	42.8	9.5	21.0
	M56	2 1/4						154	6.06	258	10.16				
	M60	2 1/2						161	6.34	262	10.31				
	M64	2 3/4						161	6.34	273	10.75				
	M68	—						167	6.57	283	11.14				
TSR+ 6	M72	2 3/4	16,670	2,500	562,020	219	8.62	167	6.57	297	11.69	34.5	76.0	14.7	32.4
	M76	3						171	6.73	308	12.13				
	M80	3 1/4						180	7.09	312	12.28				
	M85	3 1/2						180	7.09	323	12.72				
	M90	—						186	7.32	334	13.15				
TSR+ 7	M90	3 1/2	21,340	3,200	719,390	252	9.92	186	7.32	341	13.43	47.0	103.6	19.4	42.8
	M95	3 3/4						186	7.32	346	13.62				
	M100	4						192	7.56	356	14.02				
	—	—						199	7.83	356	14.02				

*TSR+ 0 is not an auto return tensioner.

NEW TSR+ 4 vs. CURRENT TSR 4

Four TSR+ tools were used to demonstrate a typical application. Using a standard air driven pump the tools were activated to full stroke then depressurised and allowed to return.

**THE NEW TSR+ 4 IS 4X
FASTER THAN THE
EXISTING TSR4 TOOL!**



TSR+

VS.



TSR

**Manufacturing, R&D,
and Operations**

Address: 8 Dufresne Loop Luling, LA 70070
Tel: 985-785-3075
Email: info@torqlite.com
www.torqlite.com

Sales Headquarters

Address: 5335 Brystone Dr. Houston, TX 77041
Tel: 713-983-7171
Email: sales@torqlite.com
www.torqlite.com

TORQLITE