

XTRA LOAD RANGE HYDRAULIC BOLT TENSIONING TOOLS

TorqLite's XTRA load range has been developed to offer 30% more load than the T-Series with a 15mm stroke.



SPECIFICATION

Designed to fit most ANSI B16.5, MSS SP-44, API17D and Norsok L005 Compact flanges.

Compatible with imperial and metric bolts from 3/4" - 4" (M20 – M100).

1500 bar maximum working pressure.

15mm Stroke.

High Load.

Optional square drive tool run down adaptor.

Available as spring return

BENEFITS

- High wear and corrosion resistant surface treatment.
- Internal features to compensate for joint misalignment.
- Tools can be connected in sequence improving operation speed and ensuring even joint compression.

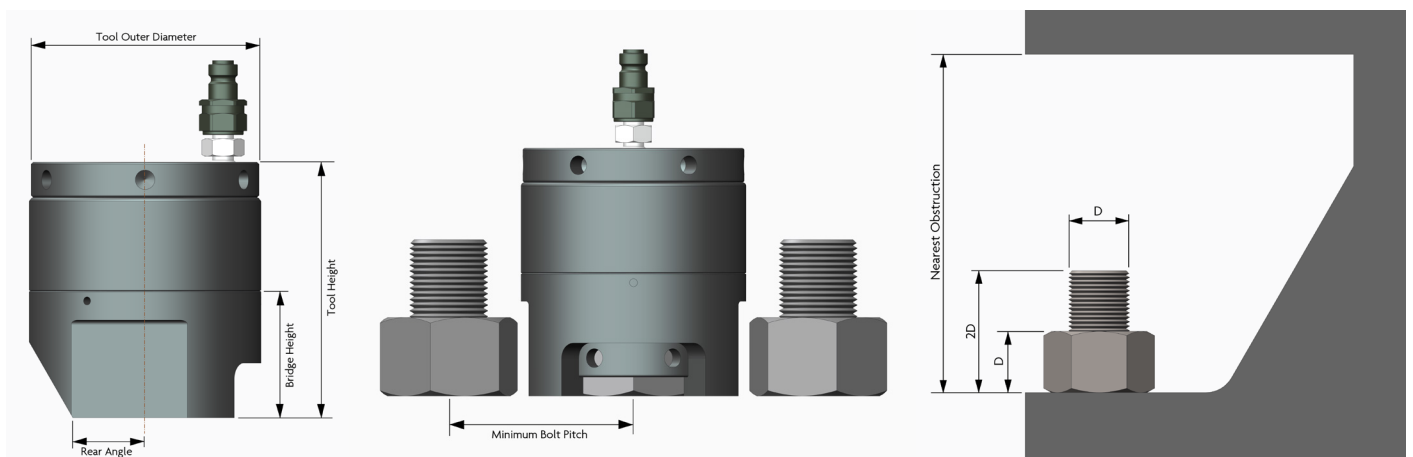

- Nut height is assumed 1 x Bolt Diameter.
- Thread pitch for metric bolt sizes will be metric coarse.
- Thread pitch for imperial bolt sizes will be UNC up to 1 inch and UN8 for 1-1/8 inch upwards.

Tool No.	Bolt Diameter		Hydraulic Area	Max Load		Tool Outer Diameter	Tool Height	Bridge Height	Rear Angle	Minimum Bolt Pitch	Nearest Obstruction	Tool Weight	
	Inch	mm		mm ²	kN							klbf	mm
C1	3/4	M20	891	134	30.1	56	85	40	14.8	48.4	158	1.3	2.9
C2	7/8	M22	1268	190	42.7	63.5	92	45	18	52.2	167	1.8	4.0
C3	1	M24	1628	244	54.9	72	99	46	24	58.6	180	2.5	5.5
C4	1-1/8	M27 M30	2154	323	72.6	83	105	50	25	62.9	191	3.4	7.5
C5	1-1/4	M33	2747	412	92.6	92	109	53	27	70.2	199	4.3	9.5
C6	1-3/8	M36	3419	512	115.3	101	114	55	31	77.2	207	5.3	11.6
C7	1-1/2	M39	4153	623	140	111	127	62	36	81	222	6	19.8
C8	1-5/8	M42	4966	745	167.5	119	131	65	37	98.4	229	8.2	18
C9	1-3/4	M45	5901	878	199	129	139	69	39	94.3	242	10.4	23
C10	1-7/8	M48	6817	1022	229.8	138	143	69	42.5	100.3	247	12.2	26.8
C11	2	M52	7856	1178	264.8	147	152	74	44	108.3	260	14.5	31.9
C12	2-1/4	M56 M60	10117	1519	341.5	167	164	79	50	120	282	20.1	44.2
C13	2-1/2	M64	12702	1904	428.2	187	181	90	55	132.8	300	26.5	58.2
C14	2-3/4	M68 M72	14084	2111	474.6	198	191	96	62	144.5	320	33	72.6
C15	3	M76	16912	2539	570.8	215	200	102	69	160.3	330	40	88
C16	3-1/4	M80 M85	20056	3006	676.9	236	219	110	69.5	170.3	362	48.3	106.3
C17	3-1/2	M90	23423	3512	789.5	250	224	115	79	185.9	370	61	134.2
C18	3-3/4	M95	27051	4058	912.2	267	246	125	80	195.3	394	69.8	153.6
C19	4	M100	30984	4648	1044.9	286	257	132	88	241.1	411	78.5	172.7

Square Drive Adaptor

Square drive adaptors are available for the Xtra load range of hydraulic bolt tensioners. Adaptors are self fixing, allowing the tool to be used upside down or horizontally. They slot into the top of the tool and work with any wrench or impact gun with a square drive which allows quick and effortless installation.

The adaptors are model specific and stamped with the model number to identify them easily. They can be transferred between imperial and metric sizes tensioners.

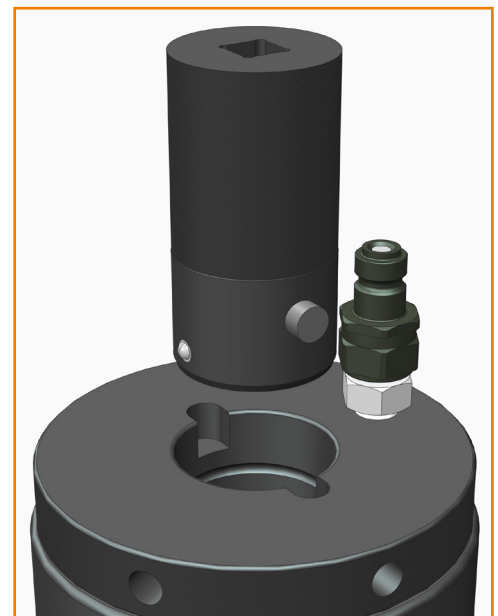

Slot the adaptor into the top of the tensioner and rapidly wind down onto the stud using a square drive wrench or impact gun.

Manufacturing, R&D, and Operations

Address: 8 Dufresne Loop Luling, LA 70070
Tel: 985-785-3075
Email: info@torqlite.com
www.torqlite.com

Sales Headquarters

Address: 5335 Brystone Dr. Houston, TX 77041
Tel: 713-983-7171
Email: sales@torqlite.com
www.torqlite.com

TORQLITE